



Deep Cycle series

Datasheet : NTD12-33(12V33AH)

Nominal Voltage	12V
Number of cell	6
Design Life	10 years
Nominal Capacity 77°F(25°C)	
20 hour rate (1.65A, 10.5V)	33.0Ah
10 hour rate (3.14A, 10.5V)	31.4Ah
1 hour rate (22.3A, 9.6V)	22.3Ah
Internal Resistance	
Fully Charged battery 77°F(25°C)	≤10.0mOhms
Self-Discharge	
3% of capacity declined per month at 20°C(average)	
Operating Temperature Range	
Discharge	-20~60°C
Charge	-10~60°C
Storage	-20~60°C
Max. Discharge Current 77°F(25°C)	330(5s)
Short Circuit Current	850A
Charge Methods: Constant Voltage Charge 77°F(25°C)	
Cycle use	2.40-2.45VPC
Maximum charging current	9.90A
Temperature compensation	-30mV/°C
Standby use	13.6-13.8V
Temperature compensation	-20mV/°C





Wide Range Temperature



Warranty



Maintenance Free



Deep cycle Technology



easy use



long life

Mechanical Characteristics

Battery (L×W×H)	mm	195×130×168
	inch	7.72×5.16×7.09
Box (L×W×H)	mm	208×143×200
	inch	8.19×5.63×7.88
Quantity Per Box		1 PC
Net weight Per Cell		10.5kg±100g
Net weight Per Box		10.5kg
Gross Weight		10.8kg

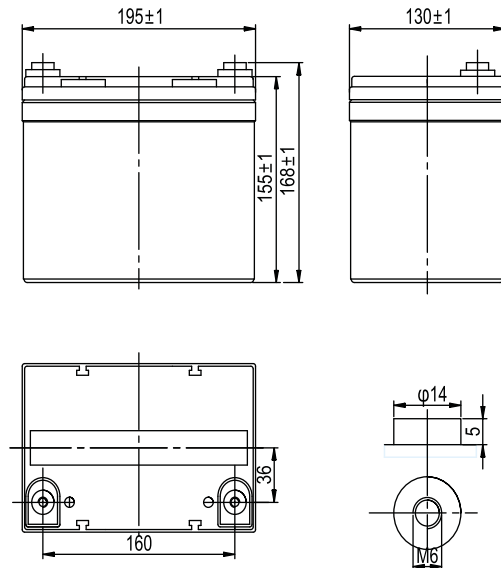

Technical Characteristics

Discharge Constant Current (Amperes at 77°F25°C)

End Point									
Volts/Cell	5min	10min	15min	30min	1h	3h	5h	10h	
1.60V	109	77.0	59.7	36.1	22.0	8.99	6.27	3.28	
1.65V	101	74.2	57.6	35.4	21.6	8.88	6.22	3.25	
1.70V	94.1	70.1	52.9	32.4	20.9	8.37	6.12	3.22	
1.75V	83.4	66.2	50.4	32.0	20.0	8.17	5.55	3.18	
1.80V	75.5	57.6	48.0	31.1	19.5	8.10	5.47	3.14	

Discharge Constant Power (Watts at 77°F25°C)

End Point										
Volts/Cell	5min	10min	15min	30min	45min	1h	2h	3h	5h	
1.60V	204	144	114	70.6	52.7	40.3	23.0	17.2	12.1	
1.65V	197	139	107	67.6	52.1	39.9	22.8	17.1	11.8	
1.70V	176	131	104	62.9	50.2	39.3	22.3	16.6	11.4	
1.75V	162	127	99.9	61.1	48.1	38.5	21.5	15.8	11.2	
1.80V	147	111	95.0	59.5	47.8	37.7	20.7	15.1	11.0	

(Note)The above characteristics data are average values obtained within three charge/discharge cycles. All data shall be changed without notice, Neata reserves the right to explain and update the information.

SHENZHEN OFFICE (CHINA)
 Tel: +86-755-2691-9474
 Fax: +86-755-2691-9474

Recognized under CE/ IEC and certified by ISO9001 ,14001



Neata[®] Deep Cycle series

Datasheet : NTD12-33(12V33AH)

+ Super energy

Discharge Characteristics Curve

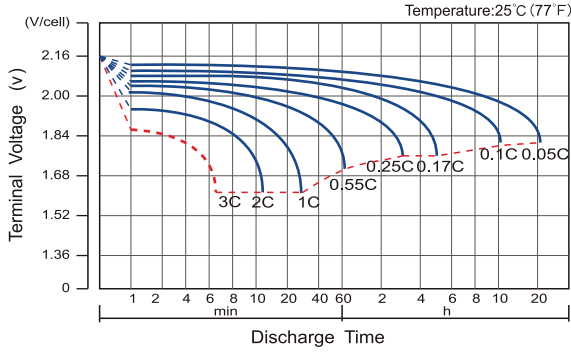

Charge Characteristic Curve For Standby Use

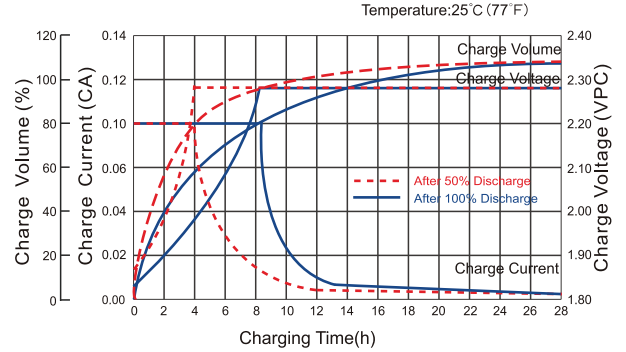

Cycle Life In Relation To Depth Of Discharge

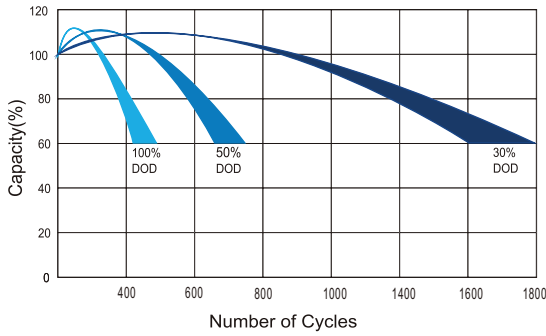

Temperature Effects On Capacity

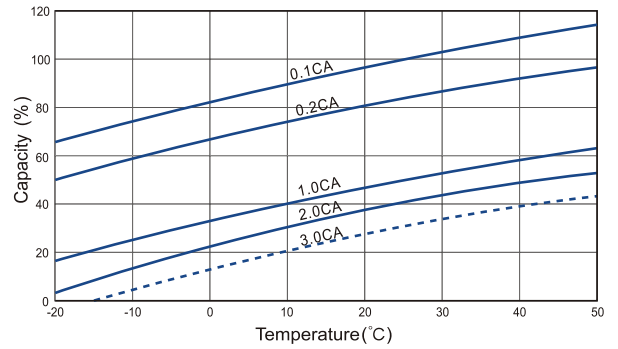

Relationship Between Charging Voltage And Temperature

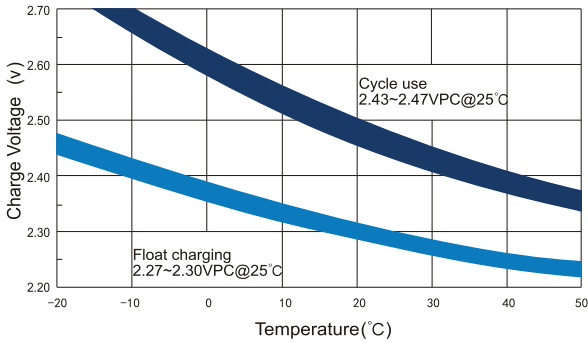

Storage Characteristics

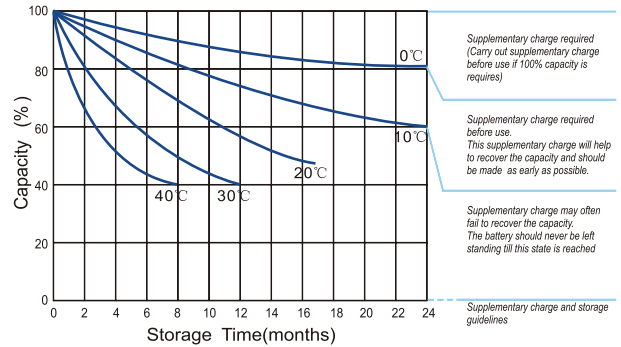

Effect Of Temperature On Long Term Life

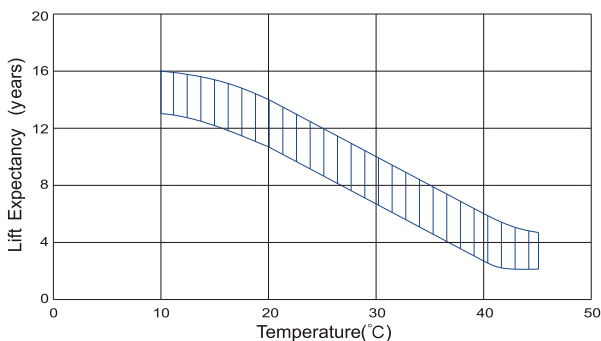

Life Characteristics Of Standby Use

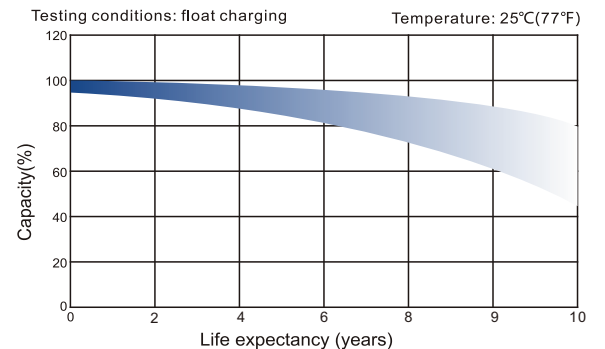

SHENZHEN OFFICE (CHINA)
Tel: +86-755-2691-9474
Fax: +86-755-2691-9474

Recognized under CE/IEC and certified by ISO9001,14001

