

Neata[®]

+ Super energy

High Power series

NTH12-5 (12V30W)

Nominal Voltage	12V
Number of cell	6
Design Life	10 years
Nominal Capacity 77°F(25°C)	
10 min wattage @1.6V	30W/cell
Nominal Capacity 77°F(25°C)	
20hour rate (0.25A, 10.5V)	5.0Ah
Internal Resistance	
Fully Charged battery 77°F(25°C)	≤35 mOhms
Self-Discharge	
3% of capacity declined per month at 20°C(average)	
Operating Temperature Range	
Discharge	-20~60°C
Charge	-10~60°C
Storage	-20~60°C
Max. Discharge Current 77°F(25°C)	75A(5s)
Short Circuit Current	370A
Charge Methods: Constant Voltage Charge 77°F(25°C)	
Cycle use	2.40-2.45VPC
Maximum charging current	2.0A
Temperature compensation	-30mV/°C
Standby use	2.23-2.30VPC
Temperature compensation	-20mV/°C



Wide Range Temperature



Warranty



Maintenance Free



High Power Design



easy use



long life

Mechanical Characteristics

Length(mm / inch)	90 / 3.54
Width(mm / inch)	70 / 2.76
Height(mm / inch)	101 / 3.98
Total Height(mm / inch)	107 / 4.21
Approx. Weight(Kg / lbs)	1.8 / 3.97

* Weight deviation: ± 5%

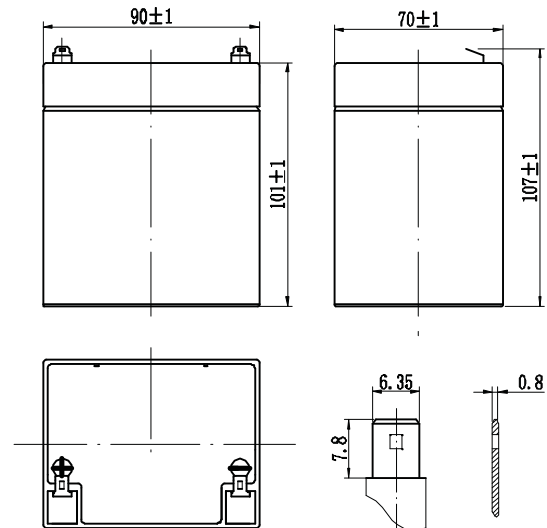

Technical Characteristics

Discharge Constant Current (Amperes at 77°F25°C)

End Point	5min	10min	15min	30min	45min	60min
1.60V	25.4	17.0	12.4	7.12	5.25	4.13
1.65V	23.9	16.0	11.7	6.75	4.99	3.94
1.70V	22.4	15.1	11.1	6.39	4.74	3.75
1.75V	20.9	14.2	10.4	6.02	4.48	3.56
1.80V	20.0	13.7	10.1	5.86	4.37	3.48

Discharge Constant Power (Watts at 77°F25°C)

End Point	5min	10min	15min	30min	45min	60min
1.60V	44.1	30.0	23.0	13.3	10.0	8.00
1.65V	42.2	28.9	22.2	12.9	9.70	7.78
1.70V	40.3	27.8	21.4	12.5	9.40	7.56
1.75V	38.5	26.6	20.6	12.0	9.10	7.34
1.80V	36.6	25.5	19.8	11.6	8.80	7.12

(Note)The above characteristics data are average values obtained within three charge/discharge cycles. All data shall be changed without notice, Neata reserves the right to explain and update the information.

SHENZHEN OFFICE (CHINA)
Tel: +86-755-2691-9474
Fax: +86-755-2691-9474

Recognized under CE/IEC and certified by ISO9001 ,14001



Neata[®] //Shenzhen Neata Power Tech co.,Ltd//www.neata-batt.com

Discharge Characteristics Curve

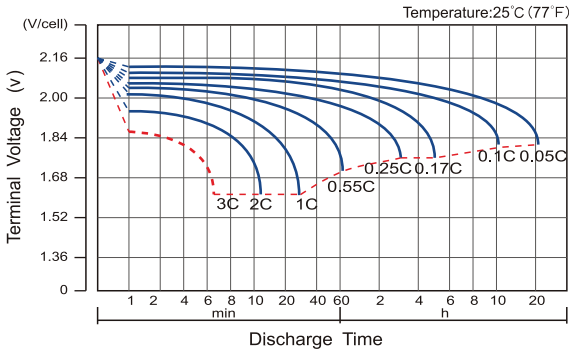

Charge Characteristic Curve For Standby Use

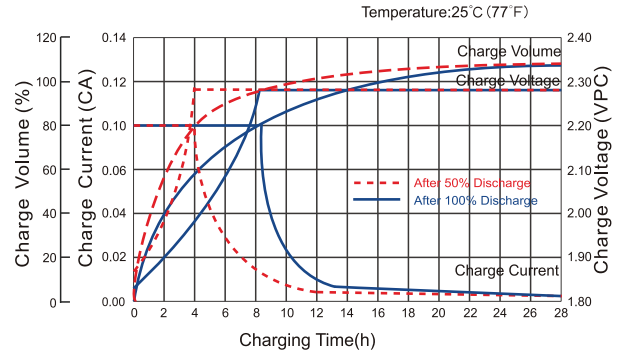

Cycle Life In Relation To Depth Of Discharge

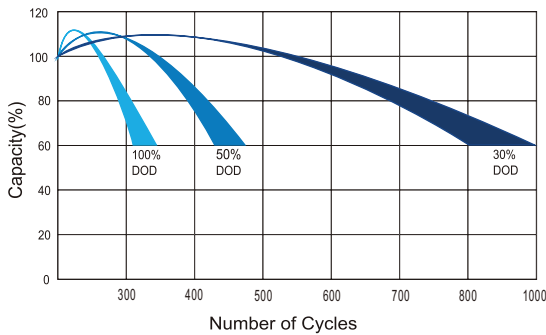

Temperature Effects On Capacity

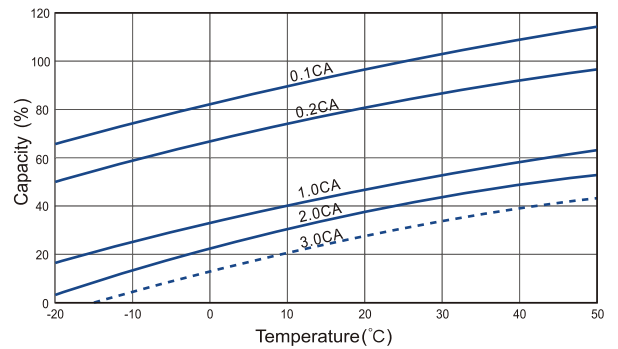

Relationship Between Charging Voltage And Temperature

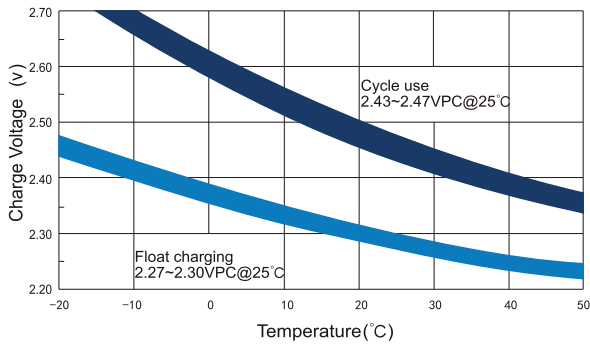

Storage Characteristics

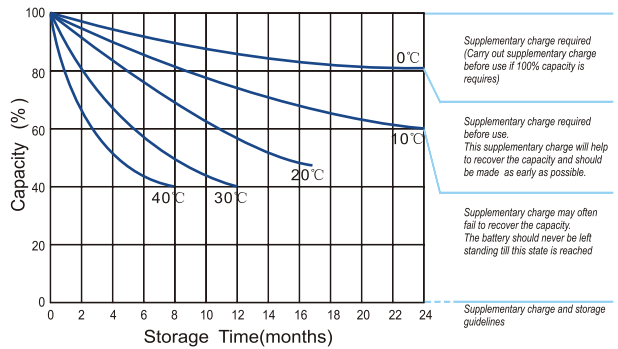

Effect Of Temperature On Long Term Life

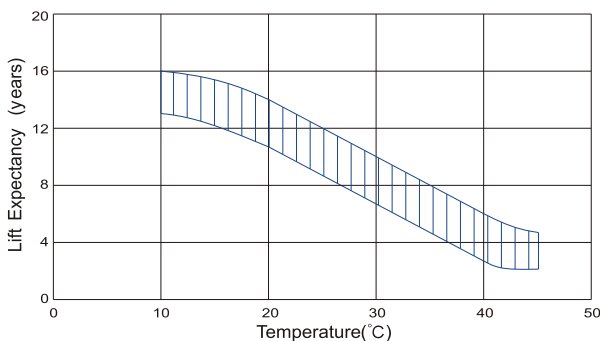

Life Characteristics Of Standby Use

